

External Technical Review Summaries



Office of Technology Innovation and Development

Office of Environmental Management

September 2011

External Technical Review Summaries

| <u>Number</u> | <u>Title</u> | <u>Report Date</u> |
|---------------|---|--------------------|
| ETR-1 | Flowsheet for the Hanford Waste Treatment Plant (WTP) | March 2006 |
| ETR-2 | Tank 48 at the Savannah River Site (SRS) | August 2006 |
| ETR-3 | Demonstration Bulk Vitrification System (DBVS) for Low Activity Waste (LAW) at Hanford | September 2006 |
| ETR-4 | Salt Waste Processing Facility Design at the Savannah River Site (SRS) | November 2006 |
| ETR-5 | Remedial System Performance Improvement for the 200-ZP-1/PW-1 Operable Units at Hanford | February 2007 |
| ETR-6 | Operational Issues at the Environmental Restoration Disposal Facility (ERDF) at Hanford | June 2007 |
| ETR-7 | Caustic Recovery Technology | July 2007 |
| ETR-8 | Building C-400 Thermal Treatment 90% Remedial Design Report and Site Investigation, Paducah, Kentucky | August 2007 |
| ETR-9 | ARROW-PAK Container | August 2007 |
| ETR-10 | Idaho CERCLA Disposal Facility (ICDF) At Idaho National Laboratory (INL) | December 2007 |
| ETR-11 | Environmental Management Waste Management Facility (EMWMF) at Oak Ridge, TN | February 2008 |
| ETR-12 | Proposed On-Site Waste Disposal Facility (OSWDF) at the Portsmouth Gaseous Diffusion Plant | April 2008 |
| ETR-13 | Mitigation and Remediation of Mercury Contamination at the Y-12 Plant, Oak Ridge, TN | April 2008 |
| ETR-14 | Disposal Practices at the Nevada Test Site | July 2008 |
| ETR-15 | Major Risk Factors Integrated Facility Disposition Project (IFDP) Oak Ridge, TN | August 2008 |

| <u>Number</u> | <u>Title</u> | <u>Report Date</u> |
|----------------------|--|---------------------------|
| ETR-16 | Proposed On-Site Disposal Facility (OSDF) at the Paducah Gaseous Diffusion Plant | August 2008 |
| ETR-17 | Plutonium Preparation Project at the Savannah River Site | October 2008 |
| ETR-18 | System Planning for Low-Activity Waste Treatment at Hanford | November 2008 |
| ETR-19 | Disposal Practices at the Savannah River Site | December 2008 |
| ETR-20 | X-701B Groundwater Remedy, Portsmouth, Ohio | December 2008 |
| ETR-21 | Evaluation of System Level Modeling and Simulation Tools in Support of SRS Liquid Waste Process, Savannah River Site | June 2009 |
| ETR-22 | Evaluation of System Level Modeling and Simulation Tools in Support of Hanford Site Liquid Waste Process at Hanford | September 2009 |
| ETR-23 | Peer Review of Advanced Simulation Capability for Environmental Management (ASCEM) at all sites | September 2011 |
| ETR-24 | Small Column Ion Exchange Technology at the Savannah River Site | September 2011 |

External Technical Review Summary

United States Department of Energy Office of Environmental Management (DOE-EM)

External Technical Review of the Flowsheet for the Hanford Waste Treatment Plant (WTP)

Why DOE-EM Did This Review



The Hanford Waste Treatment and Immobilization Plant (WTP) is being constructed to treat the 53 million gallons of radioactive waste, separate it into high- and low-activity fractions, and produce canisters of high-level (HLW) glass (left) and containers of low-activity waste (LAW) glass (right). At the time of this review, the Plant

was at approximately 70% design and 30% construction completion. *The external review objective was to determine how well the WTP would meet its throughput capacities based on the current design, identify any major issues that would prevent the WTP from operating, and identify any major or potential issues that would prevent the WTP from meeting contract rates with commissioning and future needs.*

What the ETR Team Recommended

The ETR Team recommends that the following issues be addressed to ensure throughput and reliability:

- Slurry transport piping has not been consistently designed to minimize plugging.
- Mixing systems designs were inadequate which will lead to insufficient mixing, extended mixing, vessel erosion and issues with large particles/settling.
- The WTP design has not been demonstrated to be sufficiently flexible to process all of the Hanford waste streams at design throughputs.
- Many of the process operating limits have not been completely defined making it difficult to define operating ranges for each unit operation.
- The current commissioning plans did not demonstrate long-term mission capabilities for equipment repair/remotability, especially for large and unique pieces of equipment and piping.

- The Pretreatment Facility has inadequate ultrafilter area and flux, undemonstrated leaching processes, instability in the baseline ion exchange resin, and operability and maintainability design issues.
- Adequacy of the control strategy, effect of recycle on capacity, and the decontamination factor have not been demonstrated for the evaporator design.
- Ion exchange development was inadequate including column design, cross-contamination control, valving complexity and effectiveness of cesium-137 monitoring.
- The control strategy for the LAW Vitrification Facility will likely lead to mis-batching of melter feed.
- Difficult to remove plugs will likely form in the HLW melter film cooler or the transition to the off-gas system resulting in glass production losses.
- Lack of a spare melter for both the HLW and LAW Vitrification Facilities increases the risk of loss of operation for extended periods.

What the ETR Team Found

The ETR team identified 28 issues, seventeen of which were categorized as major issues that your prevent the WTP from meeting contract rates and identified one issue, plugging, that could prevent the WTP from running consistently, and that the design approach did not minimize this risk. All of the issues are believed to be fixable without the development of new technologies and some of the fixes were already underway. The ETR team believes that the WTP project lacked a clear mission and shared vision (e.g. there was a lack of agreement about required throughput and how that translated into length of mission). Unless there is a clear mission statement, the owner and contractor cannot develop an effective shared project strategy. This includes agreement on throughput, adequacy of the basic data, and adequacy of preliminary flowsheets and piping and instrumentation diagrams.

To view the full ETR reports, please visit this web site:
<http://www.em.doe.gov/Pages/ExternalTechReviews.aspx>

July 2009

The purpose of an External Technical Review (ETR) is to reduce technical risk and uncertainty. ETRs provide pertinent information for DOE-EM to assess technical risk associated with projects and develop strategies for reducing the technical risk and to provide technical information needed to support critical project decisions. Technical risk reduction increases the probability of successful implementation of technical scope. In general, ETRs assesses technical bases, technology development, and technical risk identification and handling strategies.



EM Environmental Management

safety ❖ performance ❖ cleanup ❖ closure

www.em.doe.gov

External Technical Review Summary

United States Department of Energy Office of Environmental Management (DOE-EM)

External Technical Review of Tank 48 at the Savannah River Site (SRS)

Why DOE-EM Did This Review



Tank 48 is a 1.3 million gallon tank with full secondary containment, located and interconnected within the SRS

tank system that will play a very important role in removal and processing of high-level waste (HLW) in the years ahead. However, the tank is currently isolated from the system and unavailable for use, because its contents. It contains approximately 250,000 gallons of salt solution containing Cesium-137 and other radioisotopes which are contaminated with significant quantities of tetraphenylborate (TPB), a material which can release benzene vapor to the tank head space in potentially flammable concentrations. Plans for SRS HLW processing require removal and disposition of the contents of Tank 48 and its return to service. *The external review objective was to assess the technical viability of the current Washington Savannah River Company (WSRC) path forward for the removal, treatment and disposition of Tank 48 contents.*

What the ETR Team Recommended

The ETR Team recommends the following to improve the probability of timely success:

- Commit to Steam Reforming as the lead TPB processing approach immediately and carry Wet Air Oxidation (WAO) as a back up, to be developed to a point of assuring viability.
- Embark on a high priority heel management project, including development, testing and planning for tank flushing and the establishment of end point criteria for Tank 48 cleanliness..

- Incorporate process steps to improve schedule success (January 2010). Evaluate pre-concentration (e.g. filtration) to reduce the volume to be treated followed by transferring the bulk of the tank contents to another tank (existing or smaller constructed tank) to allow parallel heel processing and flushing. The team believes that these steps will greatly improve the probability of schedule success.
- Continue the development of steam reforming on the earliest practical schedule.

What the ETR Team Found

The ETR Team's over-arching conclusion was that while TPB processing alternatives are being properly and thoroughly evaluated, the issues necessary to achieve *timely* Tank 48 return-to-service have not been fully addressed. In the Team's view, the critical considerations for selection of a primary treatment technology include the (1) ability to produce a treated material compatible with subsequent vitrification at the Defense Waste Processing Facility (DWPF), (2) ability for the necessary process components to physically fit within the space envelope of the 241-96H facility (to avoid construction of a new radiation compliant building), and (3) process maturity to facilitate expeditious testing, design, construction and operation that is consistent to the extent possible with overall SRS schedule constraints. The two TPB processing methods chosen by WSRC as lead candidates (Steam Reforming and WAO) are technically sound, likely viable methods, and offer the best prospects for success among the approximately 80 alternatives considered. However, several areas were identified where the previous evaluations have not been sufficiently complete. Removal of residual material, tank cleanup after removal of the bulk of the material, and understanding of the form, quantities, concentrations and implications of TPB processing by-products are topics which will be very important to success.

To view the full ETR reports, please visit this web site:
<http://www.em.doe.gov/Pages/ExternalTechReviews.aspx>

July 2009

The purpose of an External Technical Review (ETR) is to reduce technical risk and uncertainty. ETRs provide pertinent information for DOE-EM to assess technical risk associated with projects and develop strategies for reducing the technical risk and to provide technical information needed to support critical project decisions. Technical risk reduction increases the probability of successful implementation of technical scope. In general, ETRs assesses technical bases, technology development, and technical risk identification and handling strategies.



EM Environmental Management

safety ❖ performance ❖ cleanup ❖ closure

www.em.doe.gov

External Technical Review Summary

United States Department of Energy Office of Environmental Management (DOE-EM)

External Technical Review of the Demonstration Bulk Vitrification System (DBVS) for Low Activity Waste (LAW) at Hanford

Why DOE-EM Did This Review



The Department of Energy (DOE) is charged with the safe retrieval, treatment and disposal of 53 million gallons of Hanford radioactive waste. The Waste Treatment Plant (WTP) is being designed to treat and vitrify the High Level Waste (HLW) fraction in 20-25 years. The WTP is undersized for vitrifying the LAW fraction over the same time frame. The DOE is evaluating Bulk Vitrification as an alternative to increasing the size of the WTP LAW treatment process. Bulk vitrification is an in-container melting process where the LAW is mixed with soil and glass formers and melted in a 50 cubic yard roll-off container. At the time of this review (2006), laboratory and pilot scale testing was in progress and the DOE had contracted to construct a full scale unit. *The objective of this external review was to determine if, as designed, the DBVS (1) could meet the requirements defined in the system specification, (2) produce waste that meets the Hanford's Integrated Disposal Facility requirements, and (3) receive operational approval by DOE and other regulators.*

What the ETR Team Recommended

- Additional cold testing and demonstration is needed for process design and operations before radioactive testing begins (e.g. dried waste feed transfer, prevention of secondary phases, testing of prototypic waste compositions, closure of the technetium and cesium mass balance, testing and safety analysis of the melt-box containment).
- The Process Control Plan should be completed

and its effectiveness tested in the full demonstration.

- The mixer-dryer and off-gas systems need special attention in the next project phase since past work has focused on In-Container Vitrification™.
- System complexity should be reduced to enhance system operability and availability.
- A better understanding of the DBVS process chemistry is critical to success, both in ensuring reliability and in troubleshooting and recovering from process issues.
- Process sampling and monitoring plans should be improved to ensure that essential data is captured from the test runs.
- Potential nuclear safety issues, including confinement strategy, implementation of Integrated Safety Management, and response to off-normal events must be resolved before radioactive operation.
- The project needs to ensure that designs and specifications meet the required codes and standards.

What the ETR Team Found

The DOE requested this review in the early stages of the project which allowed for addressing issues found in the subsequent demonstration phases. No fatal flaws were identified at the current state of the project. However, 19 technical issues that could result in a failure of the DBVS to meet established performance requirements, 26 areas of concern which could result in a change to design or additional development, and 13 suggested improvements to enhance safety, cost, schedule or efficiency were identified. The DBVS Project has conducted extensive testing ranging from crucible melts of both simulants and radioactive wastes to engineering scale melts. At the time of the review, development and demonstration had focused on glass formulation and melter system testing and demonstration. The design of other major components and systems has largely relied on limited vendor testing.

To view the full ETR reports, please visit this web site:
<http://www.em.doe.gov/Pages/ExternalTechReviews.aspx>

July 2009

The purpose of an External Technical Review (ETR) is to reduce technical risk and uncertainty. ETRs provide pertinent information for DOE-EM to assess technical risk associated with projects and develop strategies for reducing the technical risk and to provide technical information needed to support critical project decisions. Technical risk reduction increases the probability of successful implementation of technical scope. In general, ETRs assesses technical bases, technology development, and technical risk identification and handling strategies.



EM Environmental Management

safety ❖ performance ❖ cleanup ❖ closure

www.em.doe.gov

External Technical Review Summary

United States Department of Energy Office of Environmental Management (DOE-EM)

External Technical Review of the Salt Waste Processing Facility Design at the Savannah River Site (SRS)

Why DOE-EM Did This Review



The Salt Waste Processing Facility (SWPF) is intended to remove and concentrate the

radioactive strontium (Sr), actinides, and cesium (Cs) from the bulk salt waste solutions in the SRS high-level waste tanks. The sludge and strip effluent from the SWPF that contain concentrated Sr, actinide, and Cs wastes will be sent to the SRS Defense Waste Processing Facility (DWPF), where they will be vitrified. The decontaminated salt solution (DSS) that is left after removal of the highly radioactive constituents will be sent to the SRS Saltstone Production Facility for immobilization in a grout mixture and disposal in grout vaults. Parsons to design, construct, commission and initially operate the SWPF. *The external review objective was to review the Preliminary Design of the SWPF, with focus on the technical sufficiency of design to support development of a baseline cost and schedule.*

What the ETR Team Recommended

The External Review Team recommends that the following high priority technical risks be addressed:

- Completion of further design without final geotechnical data potentially could result in requiring redesign of the PC-3 Central Process Area base mat and structure due to changes in the soil-structure interaction as well as changes to the in-structure response spectra.
- Cost and schedule impacts arising from the change from ISO-9001 to NQA-1 quality assurance requirements.

- The "de-inventory, flush, and then hands-on maintenance" approach may result in unacceptable maintenance worker radiation exposure.
- The uncertainty related to the ability to procure a number of manual and automatic valves of a unique design which must be seismically qualified.
- Process or equipment impacts caused by inadequate characterization of the undissolved solids coming in with the waste feed.

What the ETR Team Found

Based upon the technical review, the following conclusions were reached:

- The SWPF project is ready to move into final design.
- Technical Issues associated with the structural design of the facility can be addressed as part of the normal design evolution. However, geotechnical investigations are behind schedule for a project at this stage of design. This represents a significant project-level risk.
- The primary processes are technically sound, and the planned large-scale equipment tests will provide very useful data to confirm and/or improve upon the current design.
- The unique operations and maintenance approach (dark cells with no expected maintenance and other equipment maintenance by flushing and hands-on maintenance) will require rigorous design and quality assurance measures to support procurement and construction.
- The current design is dependent on procuring a seismically qualified valve that isolates the process system in the event of an earthquake. The design of this valve is very different from other valves which have been seismically qualified for nuclear applications. If this valve cannot be purchased, a significant change to the current design will be required. An immediate effort should be made to determine if the valve can be procured.

To view the full ETR reports, please visit this web site:
<http://www.em.doe.gov/Pages/ExternalTechReviews.aspx>

July 2009

The purpose of an External Technical Review (ETR) is to reduce technical risk and uncertainty. ETRs provide pertinent information for DOE-EM to assess technical risk associated with projects and develop strategies for reducing the technical risk and to provide technical information needed to support critical project decisions. Technical risk reduction increases the probability of successful implementation of technical scope. In general, ETRs assesses technical bases, technology development, and technical risk identification and handling strategies.



EM Environmental Management

safety ❖ performance ❖ cleanup ❖ closure

www.em.doe.gov

External Technical Review Summary

United States Department of Energy Office of Environmental Management (DOE-EM)

External Technical Review Remedial System Performance Improvement for the 200-ZP-1/PW-1 Operable Units at Hanford

Why DOE-EM Did This Review



The 200-ZP-1 OU and PW-1 OU are pump and treat operating units (OU) designed to remove carbon tetrachloride (CT) from the groundwater and vadose zone, respectively. The units support a Comprehensive Environmental Response, Compensation, and Liability Act (CERCLA) remediation of the 200 West Area of the Hanford Site's Central Plateau. The primary contaminant of concern (COC) is CT and to a lesser extent technetium-99 (Tc-99). The groundwater extraction system consists of ten wells with capacity of 7 to 60 gallons per minute. The Soil Vapor Extraction (SVE) is conducted using one mobile extraction and treatment system, rotated among three sites for a combined period of six months per year. *This external review was a Remediation System Evaluation (RSE) of the 200-ZP-1/PW-1 groundwater and vadose zone extraction systems with the objective of identifying improvements as input to a Feasibility Study supporting the Final Record of Decision.*

What the ETR Team Recommended

- The Feasibility Study should include and evaluate the two identified conceptual models for Dense Non-Aqueous Phase Liquid (DNAPL) below the water table as a continuous source of contamination and should focus on expanded pump and treat as the primary remedial technology for groundwater.

- The remedial strategy should emphasize hydraulic containment for the most impacted portion of the groundwater plume, with compliance standards achieved at locations beyond the capture zone. These points of compliance (POC) should be identified and negotiated as soon as possible.
- The Feasibility Team should determine as soon as possible if treatment of co-contaminants (Tc-99, nitrate, etc.) will be required.
- Rapid action is recommended to inhibit further migration of Tc-99 to the water table in the TX Tanks Area versus the proposed prompt evaporation study for CT release at the Z-9 trench.
- Commonly applied and publicly accessible modeling tools should be used whenever possible. Detailed modeling to better interpret performance monitoring data should continue.

What the ETR Team Found

The ZP-1 treatment system is well run and maintained. The operators are knowledgeable and have a strong dedication to maintaining and improving the system. The Review Team believes that additional extraction wells open to deeper portions of the aquifer are needed for future contaminant extraction and plume capture. Treated water is injected back into the aquifer at three wells. The treatment removes volatile organics, but is not adequate for removing Tc-99, nitrate, or chromium. These co-contaminants warrant that the project team verify with the stakeholders that re-injection is still acceptable. The SVE is old, but has been well maintained. Budget allocations will be needed in the future for refurbishing.

To view the full ETR reports, please visit this web site:
<http://www.em.doe.gov/Pages/ExternalTechReviews.aspx>

July 2009

The purpose of an External Technical Review (ETR) is to reduce technical risk and uncertainty. ETRs provide pertinent information for DOE-EM to assess technical risk associated with projects and develop strategies for reducing the technical risk and to provide technical information needed to support critical project decisions. Technical risk reduction increases the probability of successful implementation of technical scope. In general, ETRs assesses technical bases, technology development, and technical risk identification and handling strategies.



EM Environmental Management

safety ❖ performance ❖ cleanup ❖ closure

www.em.doe.gov

External Technical Review Summary

United States Department of Energy Office of Environmental Management (DOE-EM)

External Technical Review of the Operational Issues at the Environmental Restoration Disposal Facility(ERDF) at Hanford

Why DOE-EM Did This Review



The ERDF is a large-scale disposal facility authorized to receive waste from Hanford cleanup activities. It

contains double-lined cells with a RCRA Subtitle C-type liner and leachate collection system. By 2007, 6.8 million tons of waste with 39,000 Curies of radioactivity had been placed in the ERDF. In 2006, events occurred that affected the operation of the automatic leachate transfer pumps and a technician confessed to having not performed compaction tests and to falsification of the data.

The external review objective was to assess the impacts of the following operational irregularities identified in 2006: deviations from the waste placement plan; falsification of compaction test data; adequacy of compaction testing; and failure of the leachate collection system and the failure to identify the leachate collection system failure.

What the ETR Team Recommended

The External Review Team concluded that the assessments and management plan by Washington Closure Hanford and their subcontractor (Stoller Corporation) will address the issues when fully completed and implemented. The following recommendations were made to supplement the proposed management plan:

- Permanent staff be assigned to tasks associated with each operational and management change
- Install an automated system to monitor leachate depth
- The proposed *ERDF Placement Optimization and Settlement Monitoring Test* be given priority

- Stoller should use compaction equipment that employs GPS-based grade control and stiffness-based instruments to assess compaction directly and real time.
- The settlement monitoring program should be instituted quickly and results periodically reviewed.
- Performance based methods for waste placement should be developed and implemented. This will eliminate the need for density testing.

What the ETR Team Found

The ETR team concluded that Washington Closure Hanford (WCH) and Stoller Corporation (Stoller) identified key issues that led to falsification of the compaction data and have proposed a management plan that will greatly reduce the probability of data falsification in the future. The level of oversight included in the management plan is sufficient to preclude requiring independent third party compaction testing. The ETR team also concluded that the plan proposed by WCH and Stoller to manage leachate pumping will minimize the likelihood of future unrecognized pumping system failures and excessive leachate depth in the ERDF. However, the long-term effectiveness of these changes hinges on permanent staff being assigned for direct oversight of these issues.

Because the compaction data were falsified for an extended period, significant uncertainty exists regarding the ability of the waste to provide effective support for the final cover to be placed on the ERDF. WCH has proposed a field test that will address this issue (*ERDF Placement Optimization and Settlement Monitoring Test*). The outcomes of this test, along with a settlement-monitoring program on the existing filled cells, will provide insight into the ability of the existing waste to support the final cover. This field test can also be used to assess the suitability of the 3:1 soil-debris ratio and will provide the information needed to develop a performance-based method for waste placement.

To view the full ETR reports, please visit this web site:
<http://www.em.doe.gov/Pages/ExternalTechReviews.aspx>

July 2009

The purpose of an External Technical Review (ETR) is to reduce technical risk and uncertainty. ETRs provide pertinent information for DOE-EM to assess technical risk associated with projects and develop strategies for reducing the technical risk and to provide technical information needed to support critical project decisions. Technical risk reduction increases the probability of successful implementation of technical scope. In general, ETRs assesses technical bases, technology development, and technical risk identification and handling strategies.



EM Environmental Management

safety ❖ performance ❖ cleanup ❖ closure

www.em.doe.gov

External Technical Review Summary

United States Department of Energy Office of Environmental Management (DOE-EM)

External Technical Review of Caustic Recovery Technology

Why DOE-EM Did This Review

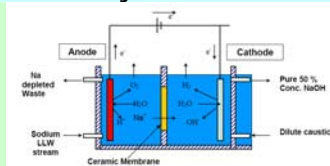

The Department of Energy (DOE) Environmental Management

Office (EM-21) has been developing caustic recovery technology for application to the Hanford Waste Treatment Plant (WTP) to reduce the amount of Low Activity Waste (LAW) vitrified. Recycle of sodium hydroxide with an efficient caustic recovery process could reduce the amount of waste glass produced by greater than 30%. The Ceramatec Sodium (Na), Super fast Ionic CONductors (NaSICON) membrane has shown promise for directly producing 50% caustic with high sodium selectivity. *The external review objective was to assess the technical maturity of the electrochemical recovery technology and the programmatic applicability of the technology to the DOE complex, specifically to the WTP.*

What the ETR Team Recommended

The External Review Team recommends:

- (1) Additional development to better understand the stability of supersaturated aluminate solutions during caustic recovery. This understanding is needed to prevent precipitation of gel aluminate and associated plugging.
- (2) Additional production and cell life testing at 50% caustic catholyte is recommended to provide the level of confidence required for deployment. At the time of the review, a single 1000 hours test at 50% caustic had been performed. Additional testing was in progress.

The ETR also recommends that a closer collaboration between Ceramatec Inc. and WTP be established to allow for more prototypic testing including expected variations in aluminum and free hydroxide concentrations. This type of testing and data would allow for an economic analysis as to the viability of caustic recovery for WTP.

What the ETR Team Found

The technology assessment team found that this electrochemical process utilizes a novel inorganic membrane technology to recover concentrated sodium hydroxide from alkaline waste typical of decontaminated ion exchange effluents from the Hanford WTP. A successfully developed technology could be used to reduce the overall sodium demands to the LAW vitrification process at WTP by recycling the sodium hydroxide for use in aluminum leaching. The consensus was that the NaSICON electrochemical process for recovering sodium hydroxide is a viable technology at its current state of development. Additional work was identified, some of which was already in progress with the Ceramatec development program. A significant amount of work had been completed including:

- Established the tape casting/lamination manufacturing process to make large area co-fired NASICON structures.
- Using a bench-scale modular unit, completed performance evaluation with several simulant compositions and actual waste.
- NaSICON ceramic membrane processing had been scaled from 1.5 kilograms per batch up to 12 kilogram per month.
- Demonstrated greater than 2000 hours of continuous operation of NaSICON membrane-based electrolytic cells to separate sodium from a typical Hanford simulant composition
- Successfully demonstrated a 5 scaffold stacked modular bench scale cell operation at 100 mA/cm²/scaffold
- Completed initial design for a full-scale operable unit

To view the full ETR reports, please visit this web site:
<http://www.em.doe.gov/Pages/ExternalTechReviews.aspx>

July 2009

The purpose of an External Technical Review (ETR) is to reduce technical risk and uncertainty. ETRs provide pertinent information for DOE-EM to assess technical risk associated with projects and develop strategies for reducing the technical risk and to provide technical information needed to support critical project decisions. Technical risk reduction increases the probability of successful implementation of technical scope. In general, ETRs assesses technical bases, technology development, and technical risk identification and handling strategies.



EM Environmental Management

safety ❖ performance ❖ cleanup ❖ closure

www.em.doe.gov

External Technical Review Summary

United States Department of Energy Office of Environmental Management (DOE-EM)

External Technical Review of Building C-400 Thermal Treatment 90% Remedial Design Report and Site Investigation, Paducah Kentucky

Why DOE-EM Did This Review

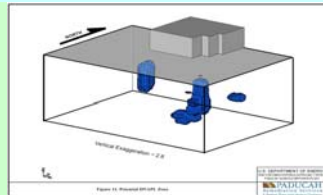

The groundwater underlying the Paducah Gaseous Diffusion Plant (PGDP) is contaminated by chlorinated solvents, principally trichloroethylene (TCE), as well as other contaminants. TCE was released as a dense nonaqueous phase liquid (DNAPL) to the subsurface soils and groundwater as a result of operations that began in 1952. The Building C-400 area is coincident with the highest TCE concentrations in the groundwater plumes at PGDP. Based on all characterization data collected to date, DNAPL residing in the Building C-400 locality represents a dominant historical and current source of TCE solvent contributing to the large PGDP groundwater plume(s). *The external review objective was to assess the proposed Electrical Resistance Heating (ERH) approach for reducing residual solvent sources present in soil and groundwater in the vicinity of Building C-400 at the PGDP to meet the interim remedial action objectives of the Record of Decision.*

What the ETR Team Recommended

- The data provide an initial basis for design/operation; however, characterization should include expanding the target treatment zones in critical areas, sampling verification during system installation to allow for adjustments, enhanced groundwater monitoring, and future sampling downgradient of the treatment zone.
- To monitor and improve performance, the TCE in the liquid recovered should be evaluated, additional technically-based metrics should be developed, the

heating target should be increased in the saturated zone beyond the co-boiling point of the TCE, and broader ERH exit strategy goals should be incorporated into the metrics.

- Based on the complex hydrogeologic setting and prior evaluations, implementation should incorporate site-specific and verified design models and sufficient flexibility and contingency.

What the ETR Team Found

The ETR Team found that C-400 TCE source zone clean-up is a challenging application of the selected Electrical Resistance Heating technology in a unique and complex setting. A significant effort with extensive analysis was evident in the 90% Remedial Design Report. The team agreed that ERH is a potentially viable remedial technology to meet the remedial action objectives adjacent to C-400. The ETR Team believes that additional efforts are needed to provide an adequate basis for the planned ERH design, particularly in the highly permeable Regional Gravel Aquifer, where sustaining target temperatures will present a challenge. The following areas also should be considered and addressed before implementation of thermal treatment:

- Accurate, site-specific models to support the ERH design for fullscale implementation for this challenging hydrogeologic setting
- Flexible project implementation and operation to allow to respond to observations and data collected during construction and operation
- Defensible performance metrics and monitoring, appropriate for ERH
- Comprehensive (creative and diverse) contingencies to address the potential for system under-performance, and other unforeseen conditions.

To view the full ETR reports, please visit this web site:
<http://www.em.doe.gov/Pages/ExternalTechReviews.aspx>

July 2009

The purpose of an External Technical Review (ETR) is to reduce technical risk and uncertainty. ETRs provide pertinent information for DOE-EM to assess technical risk associated with projects and develop strategies for reducing the technical risk and to provide technical information needed to support critical project decisions. Technical risk reduction increases the probability of successful implementation of technical scope. In general, ETRs assesses technical bases, technology development, and technical risk identification and handling strategies.



EM Environmental Management

safety ❖ performance ❖ cleanup ❖ closure

www.em.doe.gov

External Technical Review Summary

United States Department of Energy Office of Environmental Management (DOE-EM)

External Technical Review of the ARROW-PAK Container

Why DOE-EM Did This Review



The Waste Isolation Pilot Plant (WIPP) facility, located in New Mexico, is the first and only operating U.S. deep geologic repository designed for the permanent disposal of defense-related transuranic (TRU) waste. The WIPP facility provides underground disposal in a 2,000-foot-thick (610-meter) stable salt formation. Some of the waste destined for WIPP cannot be shipped in the existing approved shipping containers because it has the potential to generate hydrogen gas that exceeds the limits set by the Nuclear Regulatory Commission (NRC). The ARROW-PAK container was designed to provide a payload container for high-wattage contact handled (CH) TRU waste. The ARROW-PAK is designed to hold one high-wattage CH-TRU waste 55-gallon drum and to withstand any hydrogen deflagration event. Once loaded and sealed, three ARROW-PAK containers would be placed into one TRUPACT-II for shipment to WIPP. The ARROW-PAK and contents would be emplaced in the repository intact. *The external review objective was to evaluate (1) the technical design of the ARROW-PAK container and its potential for certification and (2) the programmatic need and the TRU inventory appropriate for the ARROW-PAK.*

What the ETR Team Recommended

- To increase the probability of success, DOE should revise the safety analysis report addendum to include better performing materials in a redesigned ARROW-PAK, consider treating ARROW-PAK as a secondary

containment system instead of a payload container, and demonstrate that it has a very low probability of failure during transportation, and that even if it fails, the consequence would be minimal due to the primary container boundary of the TRUPACT-II.

- Provide sufficient testing and safety documentation to fully address the NRC's requests for additional information (RAI) and the relevant regulations.
- A redesigned ARROW-PAK made of the alternate polyethylene material would allow an additional 120m³ to be shipped, increasing the total to 160m³.

What the ETR Team Found

The ETR Team concluded that the current approach for the ARROW-PAK container does not have a high probability for successful certification by the NRC because the NRC concerns are significant and the DOE has not addressed concerns in key areas such as applicable design and inspection codes, cold temperature behavior of fuse joints, drop test orientations, and deflagration testing pressure and temperature. The recommendations provided by the ETR would significantly improve the potential for certification. The recommendations key on complete responsiveness to the NRC's RAI and demonstrating that a redesigned ARROW-PAK meets regulatory requirements. A significant good practice noted by the ETR is that the revisions to the TRUPACT-II SAR over the last five years have increased the TRU inventory available for shipment in the TRUPACT-II thereby reducing the TRU inventory requiring the ARROW-PAK capability. The ARROW-PAK would address up to 160m³ of the existing inventory that is not currently shippable.

To view the full ETR reports, please visit this web site:
<http://www.em.doe.gov/Pages/ExternalTechReviews.aspx>

July 2009

The purpose of an External Technical Review (ETR) is to reduce technical risk and uncertainty. ETRs provide pertinent information for DOE-EM to assess technical risk associated with projects and develop strategies for reducing the technical risk and to provide technical information needed to support critical project decisions. Technical risk reduction increases the probability of successful implementation of technical scope. In general, ETRs assesses technical bases, technology development, and technical risk identification and handling strategies.



EM Environmental Management

safety ❖ performance ❖ cleanup ❖ closure

www.em.doe.gov

External Technical Review Summary

United States Department of Energy Office of Environmental Management (DOE-EM)

External Technical Review of Idaho CERCLA Disposal Facility (ICDF) At Idaho National Laboratory (INL)

Why DOE-EM Did This Review



The Idaho CERCLA Disposal Facility (ICDF) is a land disposal facility that is used

to dispose of LLW and MLW generated from remedial activities at the Idaho National Laboratory (INL). Components of the ICDF include a landfill that is used for disposal of solid waste, an evaporation pond that is used to manage leachate from the landfill and other aqueous wastes (8.3 million L capacity), and a staging and treatment facility. The ICDF is located near the southwest corner of the Idaho Nuclear Technology and Engineering Center with a disposal capacity of ~390,000 m³ (December 2007 at ~45% capacity).

The external review objective was to identify (1) issues with the ICDF design, operations and management that could impact its ability to meet performance objectives, (2) similarities to or lessons learned from Hanford's ERDF that would improve the ICDF, and (3) good practices at ICDF that would benefit other DOE sites.

What the ETR Team Recommended

- Evaluate methods used to place grout within containers to ensure that the 5% maximum void space criterion is met.
- Evaluate and utilize density methods that are more reliable than nuclear density testing for compaction testing (e.g. ASTM D 4914).
- Re-evaluate the testing strategy for the leachate alarm system to ensure frequency of testing is sufficient.

- Re-evaluate the Landfill Compaction/Subsidence Study to consider the impacts of differential settlement caused by variations in stiffness, collapse of voids, and long-term creep settlement of the wastes in the ICDF.
- Consider filling voids between containers with soil to reduce moisture contact with the waste.

What the ETR Team Found

The independent review team found no issues of immediate concern affecting the performance of the ICDF. As noted in the recommendations, the team was concerned about void space within the waste containers an assurance of meeting the 5% requirement, void space between and under containers, compaction/density determinations of compacted mixtures of soil and debris, and that the current Compaction/Subsidence study does not consider localized differential settlements.

The following noteworthy practices, beneficial to other DOE sites were identified:

- Automated monitoring of leachate collections systems and leak detection zones should be employed at all landfills operated by EM.
- Trucks equipped with mechanical arms should be considered for transporting roll-off boxes to reduce lost time and disability due to accidents associated with cable winches.
- Technologies such as RFID tags should be considered to provide tight control on the waste stream being landfilled.

To view the full ETR reports, please visit this web site:
<http://www.em.doe.gov/Pages/ExternalTechReviews.aspx>

July 2009

The purpose of an External Technical Review (ETR) is to reduce technical risk and uncertainty. ETRs provide pertinent information for DOE-EM to assess technical risk associated with projects and develop strategies for reducing the technical risk and to provide technical information needed to support critical project decisions. Technical risk reduction increases the probability of successful implementation of technical scope. In general, ETRs assesses technical bases, technology development, and technical risk identification and handling strategies.



EM Environmental Management

safety ❖ performance ❖ cleanup ❖ closure

www.em.doe.gov

External Technical Review Summary

United States Department of Energy Office of Environmental Management (DOE-EM)

External Technical Review of Environmental Management Waste Management Facility (EMWMF) at Oak Ridge, TN

Why DOE-EM Did This Review



The Environmental Management Waste Management Facility (EMWMF) is a land disposal facility for wastes generated by environmental restoration activities being conducted at the US Department of Energy's (DOE) Oak Ridge Reservation. Low-level radioactive wastes, hazardous wastes (Subtitle C of the Resource Conservation and Recovery Act), and wastes defined by the Toxic Substances Control Act are approved for disposal in the EMWMF. All of the cells are lined with a state-of-the-art double liner system. A 305-mm-thick granular layer is used for leachate collection along the base of the cells with a geocomposite drainage layer used for leachate collection on the slopes. The collected leachate is stored until transport to a separate on-site facility for treatment and disposal. *The external review objective was to identify (1) issues with the EMWMF design, operations and management that could impact its ability to meet performance objectives, (2) similarities to or lessons learned from Hanford's ERDF that would improve the EMWMF, and (3) good practices at EMWMF that would benefit other DOE sites.*

What the ETR Team Recommended

- Estimate the remaining land fill volume needed to complete remedial activities at Oak Ridge, and develop landfill expansion plans, if necessary. Pre-loading wastes, substituting thinner geosynthetic cover elements, or reducing thickness of the surface layer should be considered.

- Reduce the amount of clean soil used during disposal by accelerated phasing of landfill construction to allow lined areas for queuing debris and contaminated soils for disposal.
- Evaluate and utilize density methods that are more reliable than nuclear density testing. An increase in the required minimum waste density should be considered.
- Re-evaluate the compaction criterion, void space grouting criterion, and EMWMF waste settlement due to variations in stiffness and time-dependent compression and long-term creep settlement of the soils and debris.

What the ETR Team Found

The ETR Team found no issues of immediate concern affecting the performance of the EMWMF. There is a concern that the approved capacity of the EMWMF may not be sufficient for the remaining and non-baseline remedial actions at Oak Ridge.

- As noted in the recommendations, compaction assessment, waste settlement and impact on the cover should have a focused review to ensure long term objectives are met.
- Automated electronic control and record-keeping systems are being use for waste entering the disposal facility. Comprehensive technical guidance documents have been developed for delivery and disposal requirements. Similar systems should be considered for other DOE sites.
- Oak Ridge constructed a dedicated haul road for waste transport avoiding public road issues.
- A trust fund was established for perpetual long-term maintenance and monitoring after closure, alleviating public confidence issues.

To view the full ETR reports, please visit this web site:
<http://www.em.doe.gov/Pages/ExternalTechReviews.aspx>

July 2009

The purpose of an External Technical Review (ETR) is to reduce technical risk and uncertainty. ETRs provide pertinent information for DOE-EM to assess technical risk associated with projects and develop strategies for reducing the technical risk and to provide technical information needed to support critical project decisions. Technical risk reduction increases the probability of successful implementation of technical scope. In general, ETRs assesses technical bases, technology development, and technical risk identification and handling strategies.



EM Environmental Management

safety ❖ performance ❖ cleanup ❖ closure

www.em.doe.gov

External Technical Review Summary

United States Department of Energy Office of Environmental Management (DOE-EM)

External Technical Review of the Proposed On-Site Waste Disposal Facility(OSWDF) at the Portsmouth Gaseous Diffusion Plant

Why DOE-EM Did This Review



The On-Site Waste Disposal Facility (OSWDF) is proposed for long-term containment of contaminated materials from the planned Decontamination and Decommissioning (D&D) activities at the Portsmouth Gaseous Diffusion Plant. Acceptable performance of the proposed OSWDF will depend on interactions between engineered landfill features and operations methods that recognize the unique characteristics of the waste stream and site-specific environmental conditions. The design and environmental controls were selected to provide a greater level certainty that long-term disposal capacity would be available to support D&D and Remediation activities. *The objective of the review was to evaluate the public acceptance and regulatory processes and to provide initial input on facility design.*

What the ETR Team Recommended

1. Recognizing that public involvement is critical to acceptance, DOE will need to involve stakeholders at the beginning and create a partnership in determining siting and environmental control designs. An independently chartered organization could be created to facilitate interaction between all interested parties and DOE.

2. Documentation should be electronic and paper, presented at multiple technical levels to fully address the educational and functional interests of the stakeholders.
3. Fully communicate the strong operating record of the on-site disposal facilities in the DOE Complex and the positive impact stakeholders have had at other sites (e.g. Hanford).
4. Consider establishing a perpetual maintenance and monitoring fund at the onset to assure stakeholders of the integrity of the OSWDF over the long term.
5. The following design considerations were recommended:
(a) Site selection should avoid locations with existing ground water contamination and/or buildings, (b) Sumps should be located to one side versus centrally, (c) Provide dedicated haul roads for transporting waste, and (d) use automated methods where practical.

What the ETR Team Found

The Independent technical team found that DOE was working in all of the recommended areas of public involvement and acceptance and appeared to have incorporated lessons learned from prior disposal facility design and permitting experiences. The recommendations were provided to enhance the current efforts. The team considered the implications of CERCLA versus RCRA, but deferred the analysis to DOE to weigh the advantages and disadvantages of both approaches. Generally CERCLA addresses inactive hazardous waste sites involving past disposal issues and RCRA addresses "cradle-to-grave" management of hazardous waste. In the area of design, logistics of construction and D&D should be considered to avoid using the landfill for clean versus contaminated materials. Operations should minimize Void space by compacting and crushing waste.

To view the full ETR reports, please visit this web site:
<http://www.em.doe.gov/Pages/ExternalTechReviews.aspx>

July 2009

The purpose of an External Technical Review (ETR) is to reduce technical risk and uncertainty. ETRs provide pertinent information for DOE-EM to assess technical risk associated with projects and develop strategies for reducing the technical risk and to provide technical information needed to support critical project decisions. Technical risk reduction increases the probability of successful implementation of technical scope. In general, ETRs assesses technical bases, technology development, and technical risk identification and handling strategies.



EM Environmental Management

safety ❖ performance ❖ cleanup ❖ closure

www.em.doe.gov

External Technical Review Summary

United States Department of Energy Office of Environmental Management (DOE-EM)

External Technical Review of the Mitigation and Remediation of Mercury Contamination at the Y-12 Plant, Oak Ridge, TN

Why DOE-EM Did This Review



From 1953 to 1983, ~240,000 pounds of mercury (Hg) were released to the East Fork Popular Creek during the operation of the Y-12 Plant. In 1963, direct systematic releases of mercury stopped; however, mercury continues to be released into the creek from various sources of contamination in the Y-12 complex. Remediation completed up to 1992 resulted in an overall reduction of Hg loading from 150 g/day in 1983 to 15 g/day in 1992, with a current goal of 5g/day or less. *The objective was to review the current ground and surface water Hg remediation strategy for adequacy in reducing Hg levels in the fish and to identify opportunities to achieve cost and technical improvements and/or to address technical uncertainties.*

What the ETR Team Recommended

1. The team recommended that a plan that logically integrates the prioritized list of recommendations into a coordinated technical approach be developed with the participation of affected Oak Ridge organizations, state and federal regulators and stakeholders.
2. "Quick Wins" were recommended for near term improvements as follows:
Outfall 200- (a) use of stannous chloride in the NS Pipe to volatilize Hg, (b) addition of Hg sequestrants, and (c) use of sodium thiosulfate for dechlorination.

2. (cont'd) "Quick Wins"

Creeks and Streams- (a) selective physical modification at areas of methylation and (b) addition of trace Se to reduce methylation and/or uptake current and projected reality should be added.

What the ETR Team Found

The review/workshop focused on mercury contamination in the East Fork Popular Creek and how to reduce mercury levels in the fish. The metrics for achieving cleanup vary according to the agency of interest; however, national data suggest a clear trend toward the use of fish tissue concentration as the ultimate basis for setting standards. A significant technical observation was that the level of Hg found in the fish in the creek at Y-12 resulted from an intricate series of chemical transformations that began with the initial release of Hg followed by a series of changes as the Hg was transported through the shallow soil, to the surface and/or shallow ground water, and then through the reach of the stream drainage. The concentration of Hg in the fish, a potential remedial action endpoint, is better correlated with the concentration of methyl mercury in the stream. The biogeochemical and microbial processes that form methyl mercury from inorganic mercury are in the basic science regime and are being actively studied. Therefore, actions that reduce the fraction of Hg converted to methyl mercury within stream water and/or sediment or actions that alter the food chain dynamics are potentially important to addressing the impact of mercury at Oak Ridge. Recommendations were made by evaluation of four action zones: buildings and rubble, source zone soil, Outfall 200 area, and upper and lower reaches of the creek. The first two zones appeared to have less direct importance than Outfall 200 and the upper and lower reaches of the creek in affecting the environmental impact of mercury contamination at the Y-12 Facility.

To view the full ETR reports, please visit this web site:
<http://www.em.doe.gov/Pages/ExternalTechReviews.aspx>

July 2009

The purpose of an External Technical Review (ETR) is to reduce technical risk and uncertainty. ETRs provide pertinent information for DOE-EM to assess technical risk associated with projects and develop strategies for reducing the technical risk and to provide technical information needed to support critical project decisions. Technical risk reduction increases the probability of successful implementation of technical scope. In general, ETRs assesses technical bases, technology development, and technical risk identification and handling strategies.



EM Environmental Management

safety ❖ performance ❖ cleanup ❖ closure

www.em.doe.gov

External Technical Review Summary

United States Department of Energy Office of Environmental Management (DOE-EM)

External Technical Review of Disposal Practices at the Nevada Test Site

Why DOE-EM Did This Review



Radioactively contaminated materials from the Nevada Test Site (NTS), other DOE

facilities and other federal agencies are disposed of at NTS at two low-level radioactive waste (LLRW) management sites: Areas 3 and 5. Disposal operations at Area 3 have been discontinued, but the facility is available for future disposal. The anticipated closure date for Area 3 is 2027. Area 5 is operating and will be expanded to accept future wastes. LLRW and mixed low-level radioactive waste (MLLW) are disposed of in Area 5 in shallow (3-15 m deep) unlined trenches and pits. The MLLW unit will be closed in 2011 or when capacity is reached. *The objective of this review was to evaluate the performance and the ultimate closure of Area 5's LLRW and MLLW disposal operations at the NTS.*

What the ETR Team Recommended

1. Since waste placement and disposal operations can affect the long-term stability of the final cover, previous studies should be reviewed and updated consistent with current scientific data within and external to DOE.
2. Although prior analysis supports the use of unlined landfills at NTS, it would be beneficial to review the merits of both lined and unlined landfills for future applications at NTS.
3. Automation of processes, monitoring and record keeping should be explored for application to waste acceptance and landfill operations to improve cost effectiveness and performance.

4. Closure plans for RCRA and non-RCRA disposal facilities should consider long-term performance, sustainability with minimal maintenance and/or intervention, monitoring and long-term stewardship.
5. DOE experience in maintaining Uranium Mill Tailings Remedial Action (UMTRA) facilities should be applied when designing closures and new cells to ensure the designs are congruent with the natural setting.

What the ETR Team Found

The independent review team notes that Area 5 of NTS is in an arid and remote location where ground water is very deep and found no issues that could pose immediate problems. NTS conditions are ideal for containment and isolation of radioactive waste.

In addition, the relatively thick cover profile, the design based on natural principles, and the local hydrology of the vadose zone at NTS make water intrusion a less important issue than at other sites. Results of the lysimeter study at Area 5 have shown that a cover system employing natural principles can limit flow into underlying waste to very small amounts. This design is more flexible than conventional covers with barrier layers and therefore is less susceptible to formation of defects in response to distortion caused by settlement or seismic events. However, a plan should be developed that includes the frequency of inspection, methods that will be used to identify defects, and procedures that will be followed to repair defects that are encountered during the institutional control period.

Lessons learned in stakeholder interactions could be particularly valuable to other DOE sites. NTS's success in operating LLRW and MLLW disposal facilities with the Yucca Mountain debate in the background is a testament to the importance of this long-term relationship. Documenting or sharing in a workshop, good practices for stakeholder interactions could be a significant benefit to other sites.

To view the full ETR reports, please visit this web site:
<http://www.em.doe.gov/Pages/ExternalTechReviews.aspx>

July 2009

The purpose of an External Technical Review (ETR) is to reduce technical risk and uncertainty. ETRs provide pertinent information for DOE-EM to assess technical risk associated with projects and develop strategies for reducing the technical risk and to provide technical information needed to support critical project decisions. Technical risk reduction increases the probability of successful implementation of technical scope. In general, ETRs assesses technical bases, technology development, and technical risk identification and handling strategies.



EM Environmental Management

safety ❖ performance ❖ cleanup ❖ closure

www.em.doe.gov

External Technical Review Summary

United States Department of Energy Office of Environmental Management (DOE-EM)

External Technical Review of the Major Risk Factors Integrated Facility Disposition Project (IFDP) Oak Ridge, TN

Why DOE-EM Did This Review



Approximately two million pounds of mercury are unaccounted for at Y-12 and mercury contamination has been detected in both soils and groundwater. The IFDP will provide remediation of legacy contamination at the Oak Ridge National Laboratory (ORNL) and the Y-12 National Security Complex. The broad scope includes: 1) facility reconfiguration; 2) D&D (characterization, deactivation, decommissioning, decontamination, demolition, waste management, and disposition of excess facilities and equipment); 3) remediation of contaminated soil, ground and surface water; 4) disposition of legacy materials; and 5) landfill closure.

The objective was to review IFDP major risk factors: (1) Treatment and Disposal of large quantities of Mercury Contaminated Soil and Debris, and (2) Technical Approaches related to Facility Reconfiguration for Radioactive Waste and Low Level Liquid Waste Management.

What the ETR Team Recommended

- Perform characterization leading to high confidence projection of mercury contaminated debris/soil waste volumes by utilizing innovative, proven and accurate methods. This projection is critical to ensuring that treatment technologies and facilities (including

existing facilities) are sufficient and available.

- Develop clear, achievable metrics for mercury remediation activities. Integrate disposition of debris with similar characteristics to improve efficiency and costs effectiveness. Presume macro encapsulation of Alpha 4 debris.
- Proceed with CERCLA commitments in a disciplined but expeditious manner balancing the need for progress with continued need for processing buildings and the need to remediate beneath D&D planned structures.
- Develop waste acceptance criteria critical for stakeholder support for on-site disposal of mercury contaminated waste.
- Increase security requirements and improve assessments of risk mitigating actions for worst case safety, security, and programmatic cost and schedule impacts.

What the ETR Team Found

Overall, the ETR Team concluded there were no severe technical issues that would need to be resolved prior to continued programmatic consideration of the IFDP. Several observations were considered "overarching" in that they apply across the IFDP. These are

- (1) IFDP appears to characterize the overall level of risk in a manner appropriate for the current stage of the project
- (2) The strategic approach to integrate multiple DOE programs in addressing environmental management issues is commendable and (3) Addressing legacy waste and facilities issues as soon as practicable should assist in optimizing the total cost magnitude, risk reduction, and schedule duration.

To view the full ETR reports, please visit this web site:
<http://www.em.doe.gov/Pages/ExternalTechReviews.aspx>

July 2009

The purpose of an External Technical Review (ETR) is to reduce technical risk and uncertainty. ETRs provide pertinent information for DOE-EM to assess technical risk associated with projects and develop strategies for reducing the technical risk and to provide technical information needed to support critical project decisions. Technical risk reduction increases the probability of successful implementation of technical scope. In general, ETRs assesses technical bases, technology development, and technical risk identification and handling strategies.



EM Environmental Management

safety ❖ performance ❖ cleanup ❖ closure

www.em.doe.gov

External Technical Review Summary

United States Department of Energy Office of Environmental Management (DOE-EM)

External Technical Review of the Proposed On-Site Disposal Facility(OSDF) at the Paducah Gaseous Diffusion Plant

Why DOE-EM Did This Review

The Paducah Gaseous Diffusion Plant (PGDP) is an active uranium enrichment facility that was placed on the National Priorities List. DOE is required to remediate the PGDP in accordance with the Comprehensive Environmental Response, Compensation, and Liability Act (CERCLA). DOE is evaluating alternatives to dispose of waste generated from the remedial activities at the PGDP. One option is to construct an on-site disposal facility (OSDF) meeting the CERCLA requirements.

The objective of this review was to provide input on (1) the most effective use of the existing RCRA Subtitle D landfill, (2) site considerations such as seismic and brown versus green field, (3) the public communication plan, (4) future public use options, and (5) the baseline schedule.



Paducah Gaseous Diffusion Plant

What the ETR Team Recommended

1. Evaluate the stakeholder, regulatory, and cost issues associated with using the Subtitle D landfill for: (a) diversion of non-hazardous and non-radioactive wastes from the OSDF, (b) temporary storage of waste prior to disposal in the OSDF, and/or (c) consolidating the two disposal activities into the OSDF.

2. The brownfield site is the most logical for the OSDF. If chosen, DOE should consider innovative monitoring systems.
3. For site selection, DOE should consider the recommendations of the US Army Corps of Engineers to include both deterministic and probabilistic approaches with sensitivity analyses versus a hybrid approach. They further suggest additional site testing.
4. The public communication plan should include forming stakeholder groups that are inclusive of those affected and steps to ensure open communication paths.
5. Public use should preclude access to areas with appurtenances and to the containment cap.

What the ETR Team Found

Since the independent review occurred prior to any design, the findings were limited. However, the team felt that the Subtitle D landfill would pose a long term risk to DOE and removal/consolidation with the OSDF should be considered. Although the use of a brownfield site is logical for the Paducah OSDF, there will be considerable regulator and possibly stakeholder hurdles to address.

The team also found that at the current stage there were no evident problematic issues from a project management perspective. The ultimate public use of the closed CERCLA disposal facility should be carefully considered and be consistent with the final design and closure of the facility.

To view the full ETR reports, please visit this web site:
<http://www.em.doe.gov/Pages/ExternalTechReviews.aspx>

July 2009

The purpose of an External Technical Review (ETR) is to reduce technical risk and uncertainty. ETRs provide pertinent information for DOE-EM to assess technical risk associated with projects and develop strategies for reducing the technical risk and to provide technical information needed to support critical project decisions. Technical risk reduction increases the probability of successful implementation of technical scope. In general, ETRs assesses technical bases, technology development, and technical risk identification and handling strategies.



EM Environmental Management

safety ❖ performance ❖ cleanup ❖ closure

www.em.doe.gov

External Technical Review Summary

United States Department of Energy Office of Environmental Management (DOE-EM)

External Technical Review of the Plutonium Preparation Project at the Savannah River Site

Why DOE-EM Did This Review

The purpose of the Plutonium Preparation Project (PuPP) is to prepare for disposition of plutonium materials; for examination, re-stabilization, and disassembly of the Fast Flux Test Facility (FFTF) unirradiated fuel; and for repackaging of Pu stored in 3013 containers. Of ~12.8 MT of plutonium, ~4.1 MT will be directly transferred to the MOX Fuel Fabrication Facility (MFFF); ~3.7 MT will require processing prior to transfer to the MFFF; and ~5 MT was proposed to be processed in H-Canyon with the associated waste ultimately being vitrified. The proposed preferred alternative includes installing equipment in the K-Area Complex (KAC) in order to prepare the materials for disposition in the MFFF and H-Canyon. Processing in H-Canyon should be completed by 2019, consistent with planned closure of H-Canyon. *The objective of this review was to verify that the process, cost, and programmatic assumptions used for the PuPP approval decision-- revised critical decision (CD- IA), June 27, 2008-- were appropriate and reasonable.*



What the ETR Team Recommended

1. Due to the number of process, program, and security interfaces, DOE oversight plus the project cost and schedule planning for construction and operation should be increased. Periodic verification of planning input versus current and projected reality should be added. The time and motion study

should be revisited.

2. As the design matures, conservative safety assumptions should be revisited for cost improvement opportunities.
3. An alternate waste disposition path that is in compliance with the current Yucca Mountain plutonium license requirements should be developed for the ~5MT proposed to be processed in H-Canyon.

What the ETR Team Found

A detailed review of the PuPP primary assumptions was performed with the following findings:

1. The PuPP has a sound technical basis with a limited set of technology challenges. Most of the operations are based on demonstrated technologies with recent experience within the DOE complex, except:
 - a. The design and operation of the Pu metal furnace will require development and demonstration with a long lead time. Suitable test facilities must be identified.
 - b. A certified Pu storage container and crimping station for transfer of in-process materials between facilities should be considered.
 - c. Gadolinium as a poison and that maximum Pu concentrations within sludge batches are consistent with Yucca Mountain acceptance requirements must be validated.
2. The planning and scheduling process was not detailed enough to address the complexity of internal and external process, program, and facility interfaces. Since the FFTF fuel operation is likely to be the rate-limiting process and multiple secure material transfers are required, the time and motion studies should be upgraded.
3. During construction, the availability and scheduling of a sufficient number of appropriately skilled and cleared craft workers will be a significant challenge.

To view the full ETR reports, please visit this web site:
<http://www.em.doe.gov/Pages/ExternalTechReviews.aspx>

July 2009

The purpose of an External Technical Review (ETR) is to reduce technical risk and uncertainty. ETRs provide pertinent information for DOE-EM to assess technical risk associated with projects and develop strategies for reducing the technical risk and to provide technical information needed to support critical project decisions. Technical risk reduction increases the probability of successful implementation of technical scope. In general, ETRs assesses technical bases, technology development, and technical risk identification and handling strategies.



EM Environmental Management

safety ❖ performance ❖ cleanup ❖ closure

www.em.doe.gov

External Technical Review Summary

United States Department of Energy Office of Environmental Management (DOE-EM)

External Technical Review of System Planning for Low-Activity Waste Treatment at Hanford

Why DOE-EM Did This Review

Construction of the facilities of the Hanford site's Waste Treatment Plant (WTP) are scheduled for completion in 2017, with radioactive waste processing scheduled to begin in 2019. An estimated 23 to 35 years will then be required to complete high-level waste (HLW) vitrification. However, vitrification of low-activity waste (LAW) may extend the WTP mission duration by decades more if supplemental LAW processing beyond the capacity of the present facility is not incorporated. *The purpose of this independent review was to evaluate the options and to provide input to the LAW supplemental treatment process decision.*

What the ETR Team Recommended

The preferred option is a second LAW vitrification facility; however, if there is schedule flexibility, enhancement of the present LAW facility also is a potentially viable option.



The WTP low-activity waste, high-level waste, pretreatment, and analytical laboratory facilities under construction

What the ETR Team Found

A comparative schedule and cost analysis was carried out for four broad scenarios (or courses of action) to address LAW treatment needs. Each scenario was evaluated under the assumptions of treating 60,000 and 90,000 MT sodium. In addition, a minimum mission duration of 30 years was assumed to facilitate comparison with the present River Protection Program (RPP) plan; however, shorter mission durations may be possible with improvements in efficiency to operations. Each of the scenarios requires implementation of a different sequence of capital and operating expenses; therefore, each has a different cost-time profile, which is contained in the present worth analyses. The analysis indicates the following:

1. A second LAW vitrification facility (Second LAW and Enhanced Second LAW) would provide the most favorable present worth while making possible attainment of the current system plan mission completion date of 2049 for the full range of potential sodium quantities assumed to be treated (i.e., 60,000 to 90,000 MT sodium). This result is possible because of the flexibility in sizing the capacity of a second LAW vitrification facility and because the selection of an immobilization method and the capacity-sizing decision would not be required until 2017, allowing time to reduce key program uncertainties.
2. Inclusion of Early LAW treatment with any of the base scenarios (WTP Only, Present RPP System Plan, or Second LAW) results in an insignificant reduction in life-cycle present worth; however, non-financial benefits derived from Early LAW also warrant consideration.
3. Enhancements to the present LAW facility would result in a six-year mission extension beyond the current system plan completion date of 2049 and provide a favorable present worth under the assumption that 60,000 MT sodium would be treated.

To view the full ETR reports, please visit this web site:
<http://www.em.doe.gov/Pages/ExternalTechReviews.aspx>

July 2009

The purpose of an External Technical Review (ETR) is to reduce technical risk and uncertainty. ETRs provide pertinent information for DOE-EM to assess technical risk associated with projects and develop strategies for reducing the technical risk and to provide technical information needed to support critical project decisions. Technical risk reduction increases the probability of successful implementation of technical scope. In general, ETRs assesses technical bases, technology development, and technical risk identification and handling strategies.



EM Environmental Management

safety ❖ performance ❖ cleanup ❖ closure

www.em.doe.gov

External Technical Review Summary

United States Department of Energy Office of Environmental Management (DOE-EM)

External Technical Review of the Disposal Practices at the Savannah River Site

Why DOE-EM Did This Review



Disposal operations have been ongoing at the Savannah River Site (SRS) for over 50 years. Active disposal in E-Area, is near the center of the site.

Although a wide range of wastes are being managed at the SRS, only low level radioactive wastes (LLRW) are disposed of on site. Wastes are disposed of in unlined slit and engineered trenches, and in low activity waste and intermediate level vaults. Some wastes are isolated in place with grout and all wastes will be covered with a cap that includes a hydraulic barrier to limit precipitation infiltration. *The objective of this review was to evaluate the disposal facility design, operations, and management versus performance objectives, DOE lessons learned, and cost effectiveness.*

What the ETR Team Recommended

1. Actual or prototypical trenches should be instrumented to determine volumetric and mass fluxes. The fluxes should also be estimated by inverse modeling using plume data from legacy disposal units and compared to Performance Assessment (PA) values.
2. Field testing in prototypical trenches should be conducted to determine: the adequacy of dynamic compaction in stiffening the waste and in controlling long term total and differential settlements, the potential for long-term settlements to impact the final cover, the hydrological performance of the final cover, and the liquid flux from the base of the unlined trenches with and without the final cover.

3 The following SRS disposal practices should be considered for use at other DOE disposal facilities: (a) SRS's long-term stabilization strategy for managing waste settlement, including the use of temporary geomembrane covers. (b) SRS's Waste Information Tracking System (WITS) , a tool for tracking and management of LLRW disposed of on-site, should be adapted or developed for general use in the DOE complex. (c) A complex-wide program based on SRS's Groundwater Modeling Consistency Team would reduce ambiguity and increase confidence in modeling predictions made for DOE sites

What the ETR Team Found

The Independent Technical Team found no immediate concerns with operations at SRS that could result in issues similar to those at Hanford's Environmental Restoration Disposal Facility (EDRF). SRS waste disposal operations are consistent with the PA and good relationships exist with the regulatory agency. The operating contractor continues to identify technical issues that may affect disposal operations and to address issues using accepted engineering methods and practices.

SRS uses a performance-based approach which allows a strategy of controlled release of contaminants from the slit and engineered trenches that is fundamentally different from total containment. The SRS approach requires understanding of the interaction of the disposal system, the waste and the local environment. The PA addresses the impact of the trenches on ground water and SRS also has a vadose zone monitoring system in place to monitor radionuclides between the facility and the ground water. The limited available data was the basis for the testing recommended by the team. The SRS performance based approach has led to the good practices recommended above for application throughout the DOE complex.

To view the full ETR reports, please visit this web site:
<http://www.em.doe.gov/Pages/ExternalTechReviews.aspx>

July 2009

The purpose of an External Technical Review (ETR) is to reduce technical risk and uncertainty. ETRs provide pertinent information for DOE-EM to assess technical risk associated with projects and develop strategies for reducing the technical risk and to provide technical information needed to support critical project decisions. Technical risk reduction increases the probability of successful implementation of technical scope. In general, ETRs assesses technical bases, technology development, and technical risk identification and handling strategies.



EM Environmental Management

safety ❖ performance ❖ cleanup ❖ closure

www.em.doe.gov

External Technical Review Summary

United States Department of Energy Office of Environmental Management (DOE-EM)

External Technical Review of the X-701B Groundwater Remedy, Portsmouth, Ohio

Why DOE-EM Did This Review

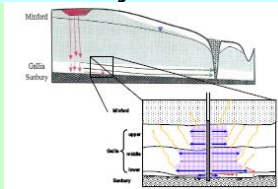

The Department of Energy (DOE) Portsmouth Paducah Project Office (PPPO) has responsibility for

remediation of the X-701B ground water plume with the key contaminant of trichloroethene (TCE). The remedy has been divided into four phases: Phase I- Initial Source Area Treatment, Phase II-Expanded Source Area Treatment, Phase III-Evaluation and Reporting, and Phase IV- Downgradient Remediation and Confirmation of Source Area Treatment. Phase II treatment has injected catalyzed hydrogen peroxide without meeting the remediation goal of $< 5\mu\text{g/L}$ TCE. *The external review objectives were: (1) to assess the ongoing oxidant-based treatment technology, (2) to provide a specific recommendation versus continuing oxidant injections and (3) to provide recommendations of alternatives to the current remediation strategy for the X-701B plume.*

What the ETR Team Recommended

The ETR Team recommends implementing innovative characterization to delineate target source zones to provide focus for future source treatments, to reduce costs, and to minimize collateral damage associated with the treatment. An overarching recommendation was to modify the pump and treat to increase effectiveness in terms of contaminant extraction rate and to support other technologies. In addition to characterization, a combination of technologies that would work synergistically should be used, since none of

the identified technologies used alone are likely to achieve remedial objectives in a timely manner. The following source remediation techniques should be considered:

- Oxidants-Consider the blending of solid oxidants, such as persulfates, beneath the former source basin (in lieu of a cap) and focusing additional injections toward the Gallia Sunbury contact using high strength long-lived oxidants. It is recommended that any oxidant method be combined with hydraulic control.
- Thermal-This technology class is potentially viable if deployment can be performed under a fixed price and guaranteed performance contract by a reliable vendor.

Soil blending of oxidant, focused TCE characterization, targeted injection of long-lived oxidant solution, and modified pump-and-treat followed by a passive technique such as wetland treatment would be an example of a simple combination of treatment technologies to be considered.

What the ETR Team Found

The independent review team found that the mass of TCE in the middle and upper Gallia source zone significantly decreased as a result of the oxidant injection, indicating measurable progress in remediation. However, the mass of TCE in the lower Gallia (near the contact with the underlying Sunbury Shale) was unchanged overall and increased in some areas. Groundwater concentrations were unchanged or increased after each Phase II injection, and all measurements of TCE in the groundwater were 100 to 10,000 times greater than the remediation goal of $5\mu\text{g/L}$. The team determined that the quantity of oxidant injected during the Phase I pilot and the first five Phase II injections was significantly less than the amount required to meet the measured soil oxidant demand. Rapid decomposition of the hydrogen peroxide and limited injection volumes likely hindered progress toward remediation goals. The time frame for success is expected to be decades versus a few years.

To view the full ETR reports, please visit this web site:
<http://www.em.doe.gov/Pages/ExternalTechReviews.aspx>

July 2009

The purpose of an External Technical Review (ETR) is to reduce technical risk and uncertainty. ETRs provide pertinent information for DOE-EM to assess technical risk associated with projects and develop strategies for reducing the technical risk and to provide technical information needed to support critical project decisions. Technical risk reduction increases the probability of successful implementation of technical scope. In general, ETRs assesses technical bases, technology development, and technical risk identification and handling strategies.



EM Environmental Management

safety ❖ performance ❖ cleanup ❖ closure

www.em.doe.gov

External Technical Review Summary

United States Department of Energy Office of Environmental Management (DOE-EM)

Evaluation of System Level Modeling and Simulation Tools in Support of SRS Liquid Waste Process

Why DOE-EM Did This Review

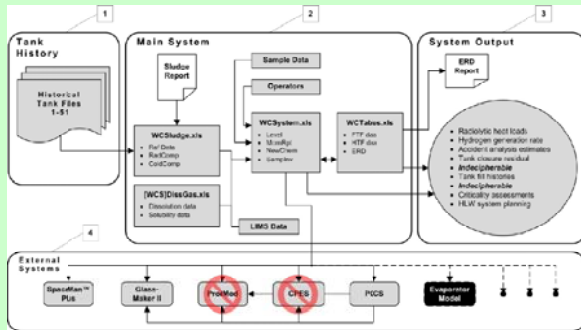

Workflow Diagram

The objective of the review was to evaluate the current Process Simulation Tools that support the planning basis for Savannah River Site (SRS) Life-cycle Liquid Waste Disposition System Plan. Specifically, the review was to: (1) assess whether the tools yield reasonable estimates; (2) evaluate methods used to model facilities currently in design, construction, planning or operational stages; (3) evaluate methods to improve the rate of system model predictions; and (4) determine if additional tools are needed to guide actual execution of individual processing steps.

What the ETR Team Found

- The current System Plan relies on a collection of software tools to organize and analyze information, and guide the processing of liquid waste. These tools currently provide “reasonable” estimates, but there is a need for an integrated system planning tool.
- The capability of current tools and their integration is limited. This hampers process optimization and mid to long-term planning.
- There is a need to increase system planning flexibility, and turnaround time at which system model predictions are done. There is a need to decouple safety, planning and operations functions.

- There is a need to relate system planning results with cost and impact of potential funding constraints. A further need is to include a waste acceptance tool for Saltstone similar to glass product acceptance.

What the ETR Team Recommended

Short-term (6 to 12 months): (1) Update computer resources (processor, memory and software); (2) Engage software engineers and modeling experts to integrate current tools; (3) Develop approach to calculate propagation of uncertainties through the planning process; (4) Review current QA software design against most recent DOE policy guide lines; (5) Develop an acceptance tool for Saltstone similar to Glass; and (6) Implement spreadsheet best practices to improve data input and integrity.

Mid-term (next 2 years): (1) Determine computing environment for long-term planning needs, including optimization and “what if” scenarios; (2) Implement approach to account for uncertainty analysis, with respect to appropriate constraints (e.g., cost, glass properties, etc.) in system plan; (3) Develop tank inventory database; (4) Implement capability to compare historical model predictions with actual data; and (5) implement integrated models to run timely system planning cases.

Long-term (3 to 4 years): (1) Implement improved planning tools for optimization and decision making; (2) Work with DOE HQ and other program offices to adopt consensus standards for material properties and RAM data across all models; (3) Integrate the tank inventory and “WCS” database; and (4) Develop the capability to ensure assumptions and calculation consistency among Safety, Planning, Operations and Waste Acceptance tools.

To view the full ETR reports, please visit this web site:
<http://www.em.doe.gov/Pages/ExternalTechReviews.aspx>

ETR Summary: September 2011

The purpose of an External Technical Review (ETR) is to reduce technical risk and uncertainty. ETRs provide pertinent information for DOE-EM to assess technical risk associated with projects and develop strategies for reducing the technical risk and to provide technical information needed to support critical project decisions. Technical risk reduction increases the probability of successful implementation of technical scope. In general, ETRs assesses technical bases, technology development, and technical risk identification and handling strategies.



EM Environmental Management

safety ❖ performance ❖ cleanup ❖ closure

www.em.doe.gov

External Technical Review Summary

United States Department of Energy Office of Environmental Management (DOE-EM)

Evaluation of System Level Modeling and Simulation Tools in Support of Hanford Site Liquid Waste Process

Why DOE-EM Did This Review

The objective of the reviews was to evaluate the current Process Simulation Tools that support the planning basis for ORP Life-cycle Liquid Waste Disposition System Plan: (1) assess whether the tools yield reasonable estimates; (2) evaluate methods used to model facilities currently in design, construction, planning or operational stages; (3) evaluate methods to improve the rate of system model predictions; and (4) determine if additional tools are needed to guide actual execution of individual processing steps.

What the ETR Team Found

- The current System Plan relies on software tools that are limited to the movement of materials. These tools currently do not predict material composition, resulting in systems at high risk of not meeting waste acceptance criteria beyond the initial batches. There is a need for a system planning tool that is chemistry based.
- Incomplete synchronization of G2 based models for tank farm operations (HTWOS) and WTP operation (G2 dynamic flowsheet) limits overall system analysis, since the current set of assumptions used by the two ORP contractors are different. HTWOS is one step behind WTP, which results in the system plan not reflecting current design/operations considerations and as a consequence timely "what if" scenarios cannot be analyzed.
- The lack of an "overall" model that addresses entire plant/process reliability, availability, and maintainability (RAM) for WTP and the Tank Farm hampers life cycle analysis. There is a need to evaluate system bottlenecks and conduct "what if" scenarios to improve process efficiency.

- The system plan needs to capture uncertainties in cost, retrieval, processing.

What the ETR Team Recommended

Short-term (6 to 12 months): (1) Update computer resources (processor, memory and software); (2) Engage software engineers and modeling experts to integrate current tools; (3) Develop approach to calculate propagation of uncertainties through the planning process; (4) Reconcile differences in assumptions between HTWOS and WTP Dynamic Flowsheet Model; (5) Link to EM-20 supported activities regarding experimentation and model development for predictive chemistry; and (6) Evaluate methods to approximate tank chemistry in HTWOS and/or WTP G-2.

Mid-term (next 2 years): (1) Determine computing environment for long-term planning needs, including optimization and what if scenarios; (2) Implement approach to account for uncertainty analysis, with respect to appropriate constraints (e.g., cost, glass properties, etc.) in system plan; (3) Consolidate HTWOS and WTP Dynamic Flowsheet Models; (4) Add "cost" module in the combined G-2 or alternative model; and (5) Incorporate expanded capabilities for chemical process modeling (thermo, kinetics and transient unit operations).

Long-term (3 to 4 years): (1) Implement improved planning tools for optimization and decision making; (2) Work with DOE HQ and other program offices to adopt consensus standards for material properties and RAM data across all models; (3) Implement unified operations research model for WTP and Tank Farms; and (4) Fully implement expanded capabilities for chemical process modeling (thermo, kinetics and transient unit operations).

To view the full ETR reports, please visit this web site:
<http://www.em.doe.gov/Pages/ExternalTechReviews.aspx>

ETR Summary: September 2011

The purpose of an External Technical Review (ETR) is to reduce technical risk and uncertainty. ETRs provide pertinent information for DOE-EM to assess technical risk associated with projects and develop strategies for reducing the technical risk and to provide technical information needed to support critical project decisions. Technical risk reduction increases the probability of successful implementation of technical scope. In general, ETRs assesses technical bases, technology development, and technical risk identification and handling strategies.



EM Environmental Management

safety ❖ performance ❖ cleanup ❖ closure

www.em.doe.gov

External Technical Review Summary

United States Department of Energy Office of Environmental Management (DOE-EM)

Small Column Ion Exchange Technology at SRS

Why DOE-EM Did This Review

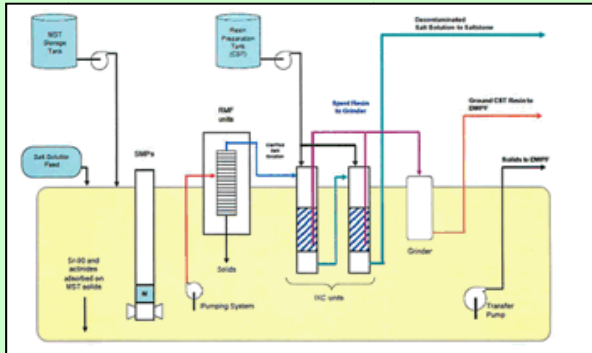

Baseline SCIX System Process Diagram

The Small Column Ion Exchange (SCIX) system is being developed at SRNL for use on high level waste. The SCIX system is composed of a series of unit operations (ion exchange, filtration, sluicing, grinding) which function to remove targeted radionuclides (Cs, Sr, and actinides) from the salt waste portion of the waste and prepare these for disposal in glass. Several critical technology elements have been identified within the SCIX system that pose a risk for successful deployment and these were the subject of this review. Specifically the critical technologies include: Cs ion exchange on a selective resin (crystalline silicotitanate [CST]) housed in an in-tank riser, grinding of the spent CST, actinide and Sr ion exchange on a resin (monosodium titanate) dispersed in the transfer tank, and solids/liquid separation by rotary microfiltration (RMF). The objective of the review was to assess the maturity of the SCIX technologies to determine the readiness of the process for completion of conceptual design, and to provide the program confidence in moving towards detailed design.

What the ETR Team Recommended

The review team identified several "areas of concern" and provided the following recommendations to address these:

- validate the CST surrogate used in grinding tests,
- accelerate testing of the highest risk individual critical technologies and perform integrated system tests using representative stimulants,
- model fluid flow through the system, with particular emphasis on flow between RMF and CST column (use integrated tests to validate),
- validate modeling (ideally with experimental tests) the thermal effects in the CST column,
- identify disposal plans for failed/spent equipment,
- close issues identified in Preliminary Consolidated Hazard Analysis,
- include schedules and rough cost estimates in maturation plan, and
- ensure that feed preparation and saltstone throughput risks are appropriately identified in risk documents, program schedules, and system plans.

What the ETR Team Found

The ETR team concluded that the SCIX system is mature enough for conceptual design and deployment by the end of 2013 is achievable, although this is an aggressive schedule. Technology risks were identified; however, these can be mitigated with appropriate testing and evaluation. The ETR team believes the greatest risks to the program are schedule related, notably procurement of long-lead items like RMFs and requiring higher production rates in tank farm operations.

To view the full ETR reports, please visit this web site:
<http://www.em.doe.gov/Pages/ExternalTechReviews.aspx>

ETR Summary: September 2011

The purpose of an External Technical Review (ETR) is to reduce technical risk and uncertainty. ETRs provide pertinent information for DOE-EM to assess technical risk associated with projects and develop strategies for reducing the technical risk and to provide technical information needed to support critical project decisions. Technical risk reduction increases the probability of successful implementation of technical scope. In general, ETRs assesses technical bases, technology development, and technical risk identification and handling strategies.



EM Environmental Management

safety ❖ performance ❖ cleanup ❖ closure

www.em.doe.gov

External Technical Review Summary

United States Department of Energy Office of Environmental Management (DOE-EM)

Peer Review of Advanced Simulation Capability for Environmental Management (ASCEM)

Why DOE-EM Did This Review

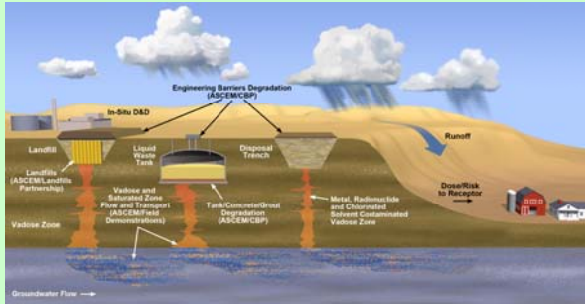

ASCEM Model Diagram

EM is faced with one of the largest and complex groundwater and soil contamination problems in the world. A major goal of EM is to move from active to passive remediation followed by long-term monitoring at DOE sites. To aid in achieving this goal, the Advanced Simulation Capability for Environmental Management (ASCEM) was initiated to develop a state-of-the-art scientific tool and approach for understanding and predicting contaminant fate and transport in natural and engineered systems. The ASCEM modeling tool will incorporate capabilities for predicting releases from various waste forms, identifying exposure pathways and performing dose calculations, and conducting systematic uncertainty quantification.

The review team was tasked with reviewing the document: *ASCEM FY10—FY15 Integrated Modeling Implementation Plan* along with supplemental information provided by program managers and staff. The primary objective was to evaluate the planning and strategic development of the ASCEM effort. At the time of the review there was insufficient information to conduct a detailed technical review, although this review will be scheduled for Q4 FY11.

What the ETR Team Recommended

The review recommended that continued periodic independent review and assessment of ASCEM be conducted to: (1) ensure application of appropriate metrics to demonstrate capability and value to EM's current and future needs, (2) determine whether the appropriate interfaces and services are being developed, and (3) enable funding sustainability. Other recommendations included:

- The critical needs of documentation of the application programming interface (API) set, along with sufficient examples and applications, should not be underestimated in their importance in meeting successful integration goals stated for the DOE's EM complex.
- In order to gain regulatory acceptance of ASCEM-derived performance assessments, it must successfully integrate disparate data and models with advances in model evaluation science (i.e., UA/SA/PE), and peta-scale high performance computing (HPC). Success is contingent upon achievement of high levels of quality-assurance throughout this integration effort (i.e., through verification, validation, documentation, independent peer review, etc).

What the ETR Team Found

The review team believes the design of ASCEM is well conceived, reasonable and consistent with scientific principles. The team also stated that an integrated, flexible and modular modeling framework has the potential to enhance knowledge integration, site characterization, and understanding of contaminant fate and transport processes, which can lead to dramatic improvements in management of DOE-EM sites, reduction of risk, and cost savings.

To view the full ETR reports, please visit this web site:
<http://www.em.doe.gov/Pages/ExternalTechReviews.aspx>

ETR Summary: September 2011

The purpose of an External Technical Review (ETR) is to reduce technical risk and uncertainty. ETRs provide pertinent information for DOE-EM to assess technical risk associated with projects and develop strategies for reducing the technical risk and to provide technical information needed to support critical project decisions. Technical risk reduction increases the probability of successful implementation of technical scope. In general, ETRs assesses technical bases, technology development, and technical risk identification and handling strategies.



EM Environmental Management

safety ❖ performance ❖ cleanup ❖ closure

www.em.doe.gov